

4-Column Presses

20 TO 1000 TON CAPACITIES

Built for Your Application

4-column hydraulic presses, also known as 4-post presses, can be designed to accommodate dies of any size and are well suited for part manufacturing that requires superior rigidity and precise bed-to-ram parallelism. 4-column presses are advantageous because they are typically more economical than gib-guided presses, and allow four-sided access to the working area.

MULTIPRESS offers a wide variety of hydraulic 4-column presses ranging from 20 to 1,000 tons in capacity. While we offer several "standard" sizes based on typical use, MULTIPRESS routinely builds customized models based on individual client application and production requirements. Our experienced engineering staff partners closely with clients to ensure their press is built to their specifications.

MULTIPRESS equipment is always built with our signature rugged, heavy duty construction, designed to meet demanding production schedules with years of trouble-free operation. *Contact us today to learn more!*



Customizable Press Options

- » T-slots
- » Die lifters
- » Die clamps
- » Dowel holes
- » Slug holes
- » Moving platens
- » Die cushions
- » Ejectors
- » Up-acting design
- » Pick & Place
- » Indexers
- » Shuttle table (manual and powered)
- » Frame size
- » Daylight
- » Stroke
- » Multi-Axis (separate ram, platen used as cushion, bottom cushion/knock-out)

Typical Configurations

- » 2-post to multiple post (4-post most common)
- » With and without moving platen(s)
- » Heated platens
- » Cushion or knock-out
- » Bolster plate

Control Choices

- » Single axis pressure reversal with position speed change
- » Multiple axis:
 - » Knockout (ejector)
 - » Cushion: single pressure
 - » Cushion: proportional (cushion pressure is variable relative to ram position)

Hydraulic Options

- » Standard directional valve type circuits
- » Open loop proportional
- » Closed loop proportional
- » Servo

Operator Safety

- » Barrier guards
- » Sliding guards
- » Light curtains
- » Presence sensing

Quality Control Options

- » Confirmed press position (monitor)
- » Confirmed press force (monitor)
- » Confirmed desired tonnage achieved within a pre-set position window
- » Process signature analysis & storage
- » Pass/fail notification

Electrical Configurations

- » Ranging from basic single cycle to automatic cycle with robotic interface
- » PLC control with operator push buttons and switches
- » PLC with touch screen
- » Touch screen with Industrial Computer / PLC
- » Windows driven touch screen with industrial computer / PLC
- » Explosion proof

Typical Specifications

Tonnage	Left to Right Between Posts	Front to Back Overall	Daylight (in)	Stroke (in)	HP	Ram Speed (IPM)		
						Advance	Press	Return
20	24	18	24	12	20	749	290	475
30	36	24	24	18	25	515	250	495
40	36	24	24	18	30	495	220	395
50	36	30	24	18	30	320	160	330
75	36	30	30	18	40	260	125	235
100	36	30	30	18	40	220	110	210
150	48	36	30	18	50	190	85	150
200	48	36	36	18	50	120	60	125
300	60	48	36	18	75	120	45	75
400	60	48	36	18	Press speeds and horsepower are quoted to meet customer cycle rate requirements.			
500	72	60	36	18				
750	72	60	36	24				
1000	72	72	42	24				

You design it... we'll quote it.

SIMPLY FILL IN THE BLANKS AND SEND THIS PAGE TO SALES@MULTIPRESS.COM, AND WE'LL SEND YOU A PROMPT QUOTATION

CUSTOMER SPECIFICATIONS:

STRUCTURE:

- FORCE: _____ TONS
- DOWN ACTING
 - UP ACTING
 - WITH GUIDED PLATEN
 - WITHOUT GUIDED PLATEN

ELECTRICAL:

- DUAL PUSH BUTTONS
- PRESSURE REVERSAL
- POSITION REVERSAL
- TIME DELAY DOWN
- OPERATING VOLTAGE
 - 230/3/60
 - 460/3/60

HYDRAULIC:

- FLOOR MOUNTED PUMP UNIT
- CROWN MOUNTED PUMP UNIT
- WATER TO OIL HEAT EXCHANGER
- AIR TO OIL HEAT EXCHANGER
- DIE CUSHION - FORCE: _____ TONS
- SPEEDS (IF OTHER THAN THOSE LISTED)
 - ADVANCE: _____ IPM
 - PRESS: _____ IPM
 - RETURN: _____ IPM

GUARDING:

- LIGHT CURTAIN
- FIXED GUARDING (DESCRIBE): _____
- _____
- OTHER: _____

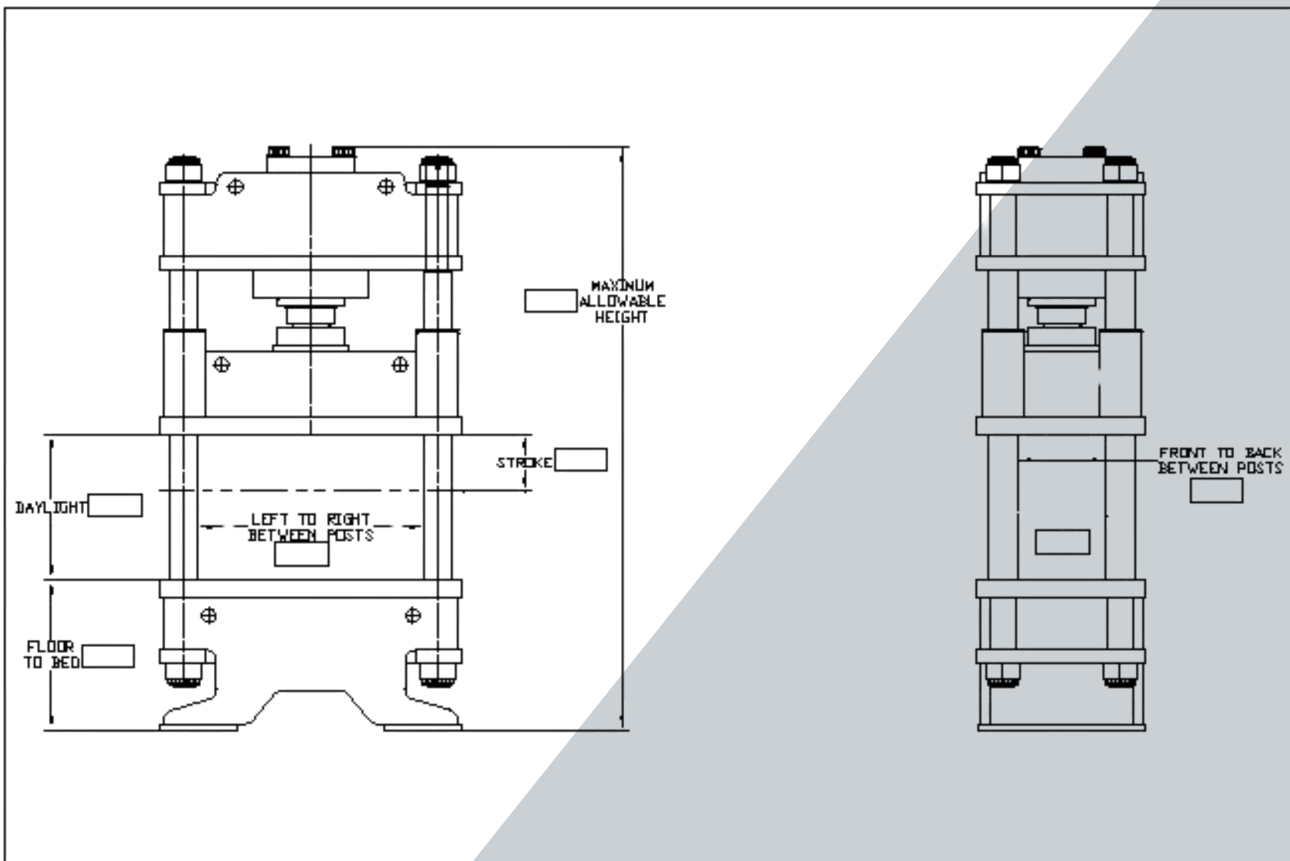

Top-Notch Support

MULTIPRESS is proud to have a service department that is equipped to provide many types of expert technical assistance, including telephone, email, and on-site help for your press.

With years of technical problem-solving experience, the MULTIPRESS Service Department stands ready to assist our customers with their service concerns. Our Service Department is committed to the maximum uptime and longevity of our customers' equipment investment. It is our assurance of prompt, reliable, and precise solutions to any concerns you may encounter in your day-to-day production.

About MULTIPRESS

For more than 80 years, Pacific Press Holdings has been trusted as the premier provider of hydraulic press solutions. Whether you are interested in a standard machine, or a completely customized design, MULTIPRESS' experts take the time to select the right machine to fit your specifications and fulfill your production requirements.

With experience in a wide variety of industries and applications, you can trust MULTIPRESS to bring reliability, productivity and precision to your operation. We proudly design and build every machine in the USA.



118-003 V1124

MULTIPRESS Inc. | A Pacific Press Holdings Company
714 N. Walnut Street – Mt. Carmel, IL 62863
sales@multipress.com | Phone: 618.262.8666 | www.multipress.com